



# INSTALLATION AND MAINTENANCE INSTRUCTIONS 6500 AND 6500S REFLECTED TYPE PROJECTED BEAM SMOKE DETECTOR

## GENERAL

The model 6500 is an addressable long range projected beam smoke detector designed to provide open area protection. It consists of a combined transmitter/receiver unit and a reflector. Smoke entering the area between the two components causes a reduction in the signal returned to the receiver. When the obscuration reaches the alarm threshold, selected at the transmitter/receiver unit, the detector generates an alarm signal. Complete blockage of the beam causes a fault signal. Slow changes in obscuration due to a build up of dirt or dust on the lens of the detector are compensated for by a micro-controller that continuously monitors the signal strength and periodically updates the alarm and fault thresholds. When the self-compensation circuit reaches its limit, the detector generates a fault signal, indicating the need for service. After local testing is complete, the yellow LED will blink a pattern to indicate the level of drift compensation employed during the test (see Blinks Output by Yellow LED table at back of manual).

The model 6500S includes an integral servo controlled calibrated test filter, which allows automatic remote alarm testing.

## SPECIFICATIONS

### General

Range:	5 to 70m 70 to 100m using optional accessory 6500-LRK/BEAMLRK
Sensitivity:	Level 1 = 25% (1.25dB) Level 2 = 30% (1.55dB) Level 3 = 40% (2.22dB) Level 4 = 50% (3.01dB) Level 5 = 30% to 50% Adjusting (Acclimate) Level 6 = 40% to 50% Adjusting (Acclimate)
Maximum angular misalignment	Detector ± 0.5° Reflector ± 10°

### Environmental

Temperature:	-30°C to 55°C
Humidity:	10% to 95% Relative Humidity (Non-condensing)

### Mechanical

Dimensions (Without Faceplate):	229mm x 178mm x 84mm
Dimensions (With Faceplate):	253mm x 193mm x 84mm
Wiring:	0.3 mm <sup>2</sup> to 3.2 mm <sup>2</sup>
Adjustment Angle:	±10° Horizontal and Vertical

### Electrical

Voltage:	15 to 32 VDC (15-28.5V when using isolators)
Avg. Standby Current:	2mA @ 24VDC; 1 comm. every 5sec, LED flashing. Read 16 sec. LED blink 8 sec
Advanced Protocol Mode:	
Max. Alarm Current (LED on):	8.5mA
Max. Fault Current (LED on):	4.5mA
Max. Alignment Current:	20mA
External Supply (for 6500S auto -alarm test only)	Voltage: 15 to 32 VDC Current: 0.5A Max.
Remote Output (alarm):	Voltage: 15 to 32VDC Current: 6mA to 15mA. Limited by 2.2KΩ resistor

## PARTS LIST

Description	Quantity
Transmitter/Receiver Unit	1
Paintable Trim Ring	1
Reflector (REFL6500)	1
Plug-in Terminal Blocks	3
Isolator Shunts	2
Orange Alignment Assistance Label	1
Instruction Manual	1

## APPROVED ACCESSORIES

### 6500-LRK/BEAMLRK

Long Range Kit comprising three additional 20cm x 20cm reflectors, which may be mounted in a square with the supplied reflector, permitting the detector to be used for ranges from 70m to 100m.

### 6500-MMK/BEAMMMK

Multi-Mounting Kit allowing the 6500 to be mounted to ceilings, or to walls where the detector and reflector cannot be mounted within 10° of one another. One kit mounts either the transmitter/receiver unit or reflector. If the transmitter/receiver is mounted on the MMK, then the 6500-SMK/BEAMSMK must be used. Note that only a single 20cm x 20cm reflector can be mounted using the MMK: The 6500-LRK/BEAMLRK is not compatible with the MMK.

### 6500-SMK/BEAMSMK

Surface Mounting Kit for the transmitter receiver (also used in combination with the 6500-MMK/BEAMMMK) to give an additional 43mm depth to assist surface mounting and to permit side entry cabling.

### RTS151KEY

Remote test and annunciator accessory that enables the detector to be tested remotely, providing test and reset functions, it has a Red LED to indicate alarm conditions (Note: Back-box, if required, needs to be ordered separately - part number WM2348).

## DETECTOR MOUNTING

### Location

The 6500 must be located in accordance with local standards and guidelines, for example BS5839 part 1. For general information, refer to the application guide for projected beam smoke detectors available on request from your supplier.

### Mounting Position

Beam detectors require a very stable mounting surface for proper operation. A surface that moves, shifts, vibrates, or warps over time may cause false alarm or fault conditions. Initial selection of a proper mounting surface will eliminate nuisance alarms and fault signals. Mount the detector on a stable mounting surface such as brick, concrete, a sturdy load-bearing wall, support column, structural beam, or other surface that is not expected to experience vibration or movement over time. DO NOT MOUNT the beam detector on corrugated metal walls, sheet metal walls, external building sheathing, external siding, suspended ceilings, steel web trusses, rafters, non-structural beam, joists, or other such surfaces. The reflector has a much greater tolerance to movement than the transmitter/receiver, hence in cases where only one stable mounting surface as defined above can be used, the transmitter/receiver unit should be mounted to the stable surface. See specifications for maximum permissible angular misalignment; movement outside these limits may cause nuisance alarms and faults.

### Mounting Considerations

- There must be a permanent clear line of vision between the detector and the reflector.
- Reflective objects should be a minimum of 380mm from the line of sight between the detector and reflector to avoid compromise of the protected area by reflected light.
- Direct sunlight or strong lights into the transmitter/receiver unit should be avoided. There should be a minimum of 10° between the paths of the light source and the detector beam.
- Operation of the detector through panes of glass should be avoided if possible. If it is necessary to pass through glass, the angle between the beam and glass should be set a minimum of 10° off perpendicular, and operation through multiple panes should be avoided.

## MOUNTING

The transmitter/receiver unit may be mounted directly to the wall, with rear cable entry. The detector base has four primary mounting holes, one in each corner of the base. All four holes must be used to provide secure mounting. In order to mount the detector to the wall, the outer cover must be removed after unscrewing its four retaining screws.

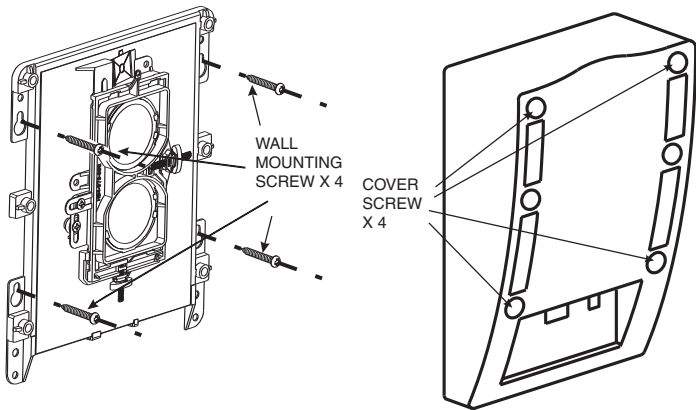
ENGLISH

ITALIANO

ESPAÑOL

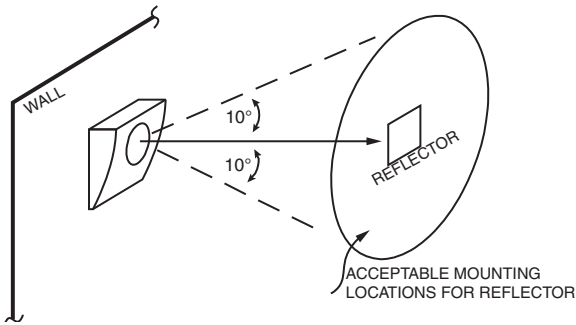
DEUTSCH

Please refer to the relevant kit instructions if the transmitter/receiver is to be mounted onto the 6500-SMK/BEAMSMK or 6500-MMK/BEAMMMK allowing more flexibility for cable entry.

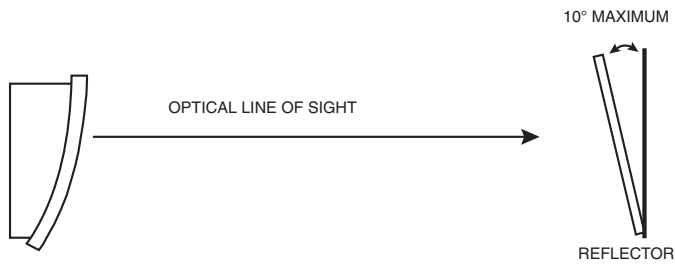


**Figure 1: Transmitter/Receiver Wall Mounting**

The reflector is mounted directly to the wall using all four of its mounting holes, one in each corner. The reflector must be mounted such that the plane of the reflector is perpendicular to the optical line of sight to the transmitter/receiver unit. The maximum tolerance for non-perpendicular mounting locations is 10°. If this tolerance is not possible, then the 6500-MMK/BEAMMMK should be used, see 6500-MMK/BEAMMMK instructions for mounting details.



**Figure 2a: Reflector Mounting Guidelines**

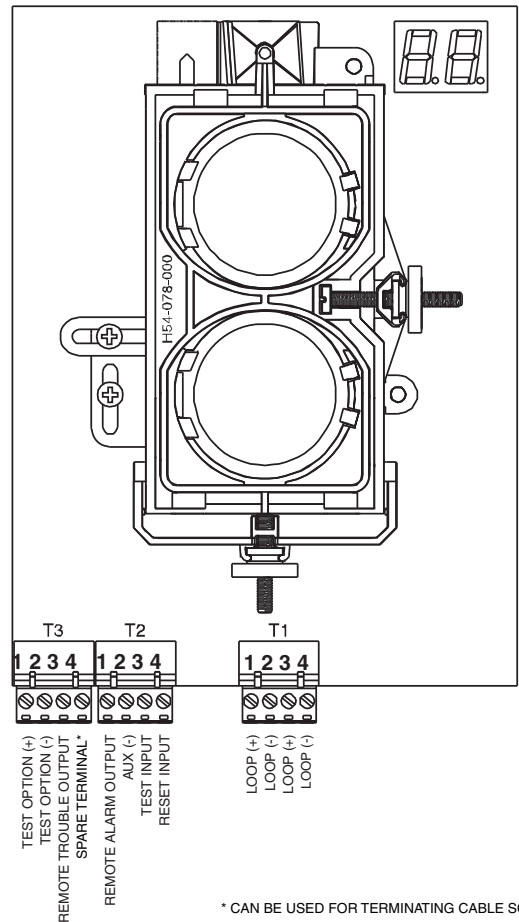


**Figure 2b: Reflector Mounting Guidelines**

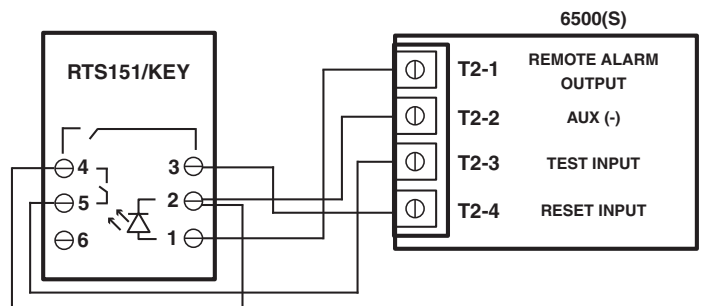
**WIRING**

Note: All wiring must be installed in accordance with local requirements.  
 Warning: Before working on the system, notify the proper authorities that the system is undergoing maintenance and will be temporarily out of service.

Wiring connections are made to pluggable terminal blocks, which can accept wire sizes from 0.3 mm<sup>2</sup> to 3.2 mm<sup>2</sup>. For best results screened cable should be used. Refer to the control panel instructions for cable type limitations.



**Figure 3: Detector Terminal Connections**



SEE RTS151KEY INSTALLATION INSTRUCTIONS FOR ELECTRICAL RATINGS OF RTS151KEY

**Figure 4: RTS151KEY Wiring**

Signal Name	Terminal	Normal State	Active State	Comment
Reset Input to	T2-4	High impedance	0V	Momentarily connect Aux- to operate
Test Input to	T2-3	High impedance	0V	Momentarily connect Aux- to operate
Aux-	T2-2	0V	-	Internally connected to Power -ve
Remote Alarm Out	T2-1	High impedance	+24V	Via 2.2k ohms current limit resistor
Remote Fault Out	T3-3	High impedance	+24V	Via 2.2k ohms current limit resistor

**Table 0: Use of Input – Output Signals.**

**WARNING**

All INPUT and OUTPUT signal terminals are active LOW (0V) Do not connect any other voltage to these terminals or serious damage to the product may result.

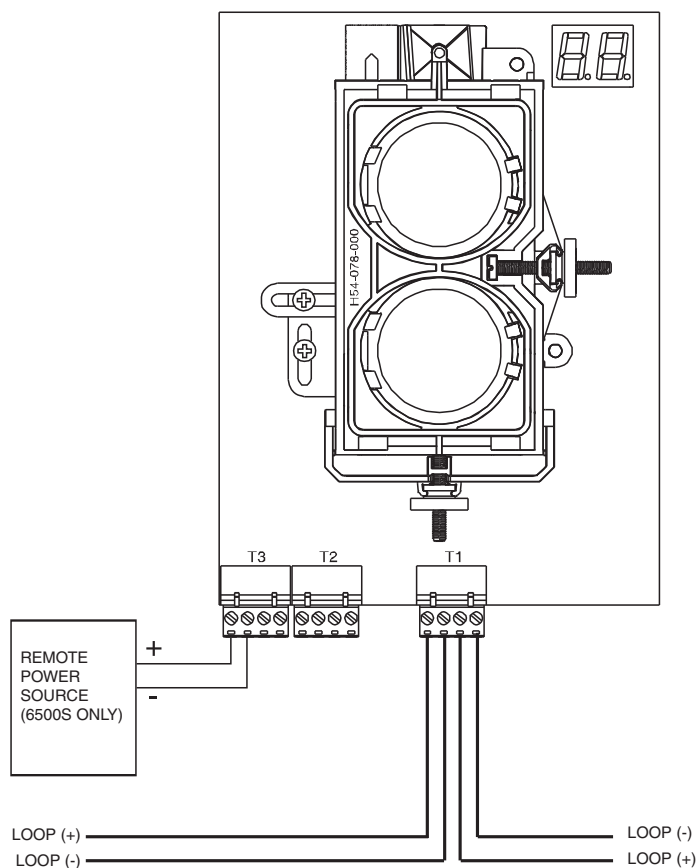


Figure 5: Wiring Diagram

### ADDRESS SELECTION

Set the sensor address (see Figure 6) by using a flat blade screwdriver to turn the two rotary switches to the left of the main optical assembly, selecting the desired number between 01 and 159 (Note: The number of addresses available will be dependent on panel capability, check the panel documentation for information on this). A breakaway stop on the **Tens** rotary switch needs to be removed for panels capable of handling more than 99 addresses.

### SHORT CIRCUIT ISOLATION

The detector includes on-board short circuit isolation. In cases where it is not desired the isolator can be bypassed using the two shunts on the circuit board. See Figure 6 for jumper locations. The detector is supplied with the jumpers fitted and the isolators bypassed.

### ALIGNMENT PROCEDURE

**Warning:** When power is initially applied to the detector, before the alignment procedure has been completed, it may enter fault or alarm. To prevent unwanted alarms, disable the zone prior to applying power.

The alignment of the 6500 is divided into four steps: Coarse alignment, fine adjustment, final gain adjustment, and final verification. It is necessary for all four steps to be executed properly to ensure proper alignment of the product.

### Pre-Alignment Checklist

- Ensure that both the detector and reflector are mounted securely to stable surfaces.
- Ensure that all wiring is correct, and that terminal blocks are fully seated into their receptacles on the detector.
- Complete any wiring dressing to minimize movement to the detector once the alignment procedure is completed.
- Ensure that the appropriate reflectors are used for the installed distance.
- Ensure that the line of sight between the detector and reflector is clear and that reflective objects are a minimum of 380mm from the line of sight.
- Ensure that both the detector and reflector are mounted within their operational parameters for off axis angles.

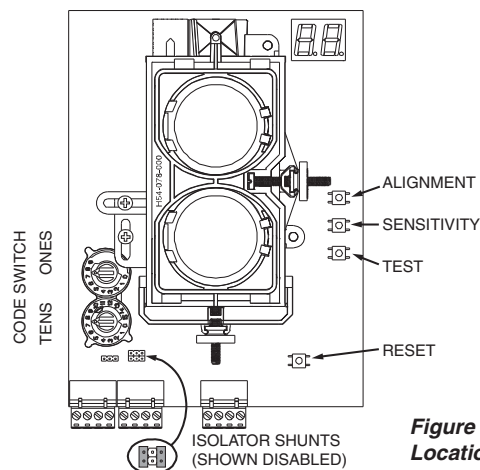


Figure 6: Switch Locations

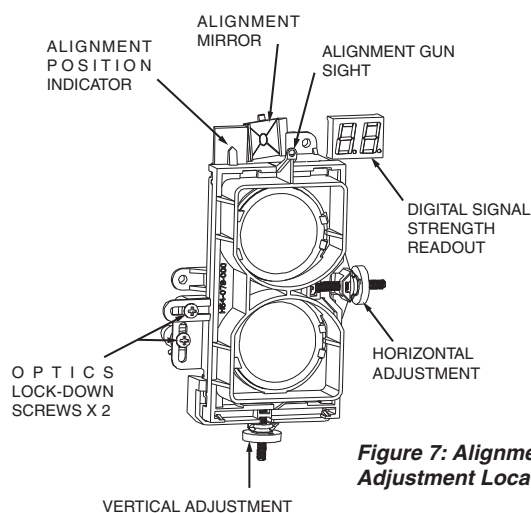


Figure 7: Alignment Adjustment Locations

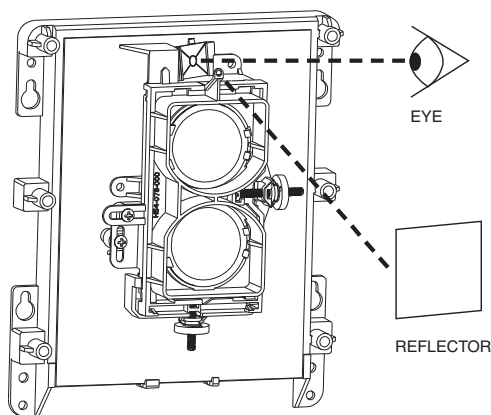
- Disable the zone or system to prevent unwanted alarms before applying power.
- Ensure power to the detector is "ON".
- Normally, due to the current drain during alignment, only one unit on a loop should be in alignment mode at any time

### Step 1. Coarse Alignment

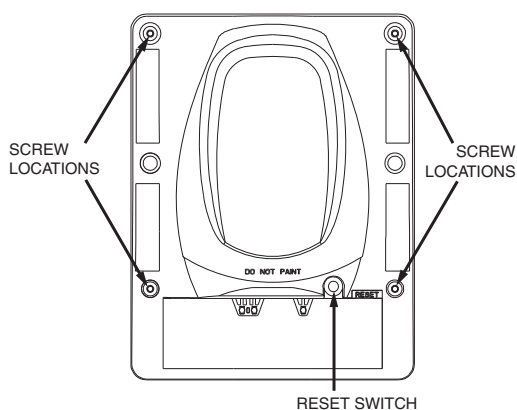
See figures 6 and 7.

1. Ensure that both of the optics lock-down screws are loosened so that the optics will move freely.
2. Looking through the alignment mirror at both the alignment gun sight and reflector simultaneously, locate the position of the reflector in the optical sight. Note that initially this step will require some practice. An orange sticky label is supplied, which may be temporarily mounted next to the reflector to aid initial location if the distance between the reflector and the detector is large.
3. Once the reflector has been located, begin to adjust both the horizontal and vertical alignment knobs so that the reflector becomes centered in the alignment mirror. Caution: If the optics are incorrectly aligned in this step, it will not be possible to proceed with the next step.

Note that the coarse alignment procedure will not give accurate alignment. It is sufficient only as a starting point for the next step. On completion of the fine adjustment procedure, the alignment gun sight may not appear to be centred on the reflector.



**Figure 8: Coarse Alignment Procedure**



**Figure 9: Housing Screw Locations**

### Step 2. Fine Adjustment

See figures 6 to 8.

1. Ensure that no objects are in the line of sight between the detector and the reflector.
2. Depress the Alignment switch once. Both the digital display and the yellow LED should turn on indicating that alignment mode has been entered. The display should begin reading “- -” signifying an electronic gain adjustment. After a few moments the display will indicate a numeric value near 20.

Note: If the display reads “Lo” then the detector is not receiving enough light from the reflector. Go back and repeat the course alignment step and verify that the proper number of reflectors is used for the installed distance. The display will continue to read “Lo” until the detector receives enough light from the reflector to continue with the fine adjustment step.

Note: In alignment mode (indicated by the yellow LED and the numeric display) the sensitivity select and test switches are disabled.

3. Once the display shows a number, begin adjusting the horizontal and vertical alignment knobs one at a time to increase signal level on the display. Continue adjusting each axis one at a time going back and forth between them until a peak value is indicated. If a value of 90 is achieved, the detector will reduce its electronic gain. This will be indicated by a “- -” reading on the display. When this happens halt any further adjustment until the display again reads a numeric value. This process may occur more than once during the fine adjustment step.
4. Once satisfied that it is not possible to achieve a higher reading on the display depress the alignment switch to complete the fine adjustment step. The digital display readout will turn “OFF” and the yellow LED will remain “ON”.

5. Ensure that both of the optics lock-down screws are re-tightened.

Note: It may not be possible to achieve a figure close to 90 on the display during the last adjustment iteration. Each time the figure 90 is reached the gain is reduced, making it more difficult to achieve high values. Any number is acceptable, provided it is the highest figure that can be achieved after the final gain adjustment.

At this time it is sensible to set the sensitivity of the detector using the sensitivity switch and digital display. See SENSITIVITY SELECTION for further details.

### Step 3. Final Gain Adjustment

See figure 9.

In this step, the detector electronically adjusts its internal gain one final time. It is necessary to complete this step with the outer housing installed since the housing will change the amount of light received from the reflector.

1. Install the outer housing of the detector. The housing is installed by tightening the four captive screws, one in each corner of the housing.

Note: The housing contains a gasket seal that protects the detector circuitry from corrosion and moisture. To ensure that this gasket performs correctly, it is necessary to tighten all four of the screws holding the outer housing in place evenly.

2. Remove the protective film from the front surface of the outer housing. Note that the outer housing may require cleaning if any residue remains. Use only a soft, damp cloth: Do not use any solvents.
3. To initiate the final electronic gain adjustment, the reset switch must be depressed using a small screwdriver or similar tool. Once depressed the yellow LED will begin to blink. On completion, the yellow LED will stop blinking and the green LED will begin blinking (dependant on panel operation), indicating that the gain adjustment was successful.

Note: Use caution not to block the line of sight between the detector and reflector in this step.

4. Install the outer aesthetic ring by snapping it onto the outer housing.

Note: If the outer aesthetic ring has been painted ensure that the paint is completely dry before proceeding with this step.

### Step 4. Final Verification

This step is required to ensure the detector has been set up correctly and will detect smoke at the proper sensitivity level.

1. With the detector functioning (dependant on the operation of the control panel, this may be indicated by the green LED blinking), completely block the reflector with a non-reflective opaque material. After about 30 seconds, the detector should enter either the fault or alarm condition. If the detector does not enter the fault or alarm condition, there is a problem with the installation.
2. Complete a sensitivity test of the detector as described in SENSITIVITY TESTING below.

### SENSITIVITY SELECTION

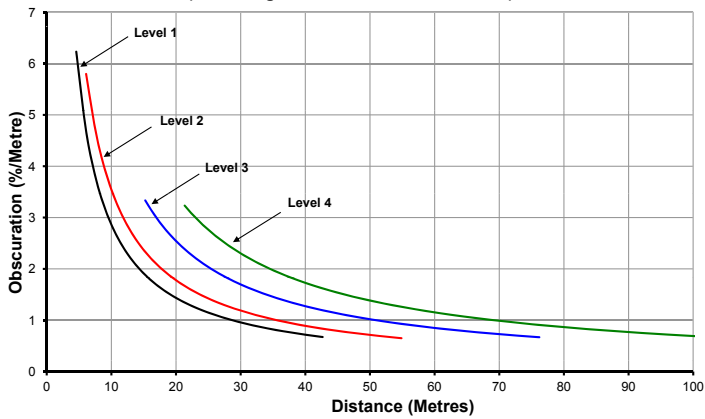
The sensitivity of the detector can be set only when the housing is removed and the detector is not in the fine adjustment step of the alignment mode. To enter the selection mode, press the sensitivity button once (see figure 6). The digital display will illuminate and read the current sensitivity setting in percent obscuration. Press the sensitivity button again to rotate to the next setting. Once the required setting is achieved (See table 1), the detector will exit the sensitivity selection mode if no further switch presses occur.

In addition to the four standard sensitivity selections the detector has two Acclimate settings. When either of these settings is chosen the detector will automatically adjust its sensitivity using advanced software algorithms to select the optimum sensitivity for the environment. The sensitivity will be continuously adjusted within the ranges specified in the Chart 1.

Sensitivity Setting	% Obscuration	Display Reading
Level 1	25	25
Level 2	30	30
Level 3	40	40
Level 4	50	50
Acclimate Level 1	30 to 50	A1
Acclimate Level 2	40 to 50	A2

**Table 1: Sensitivity Settings**

**GRAPH 1: SENSITIVITY (%M vs DISTANCE)  
(Assuming Uniform Smoke Distribution)**



Percentage obscuration can be converted to percent per metre assuming uniform smoke density for the entire length of the beam. Chart 1 converts obscuration to percent per metre for all acceptable sensitivity settings.

### SENSITIVITY TESTING

#### NOTES:

1. Before testing, notify the proper authorities that the smoke detector system is undergoing maintenance, and therefore the system will be temporarily out of service. Disable the zone or system undergoing maintenance to prevent unwanted alarms.

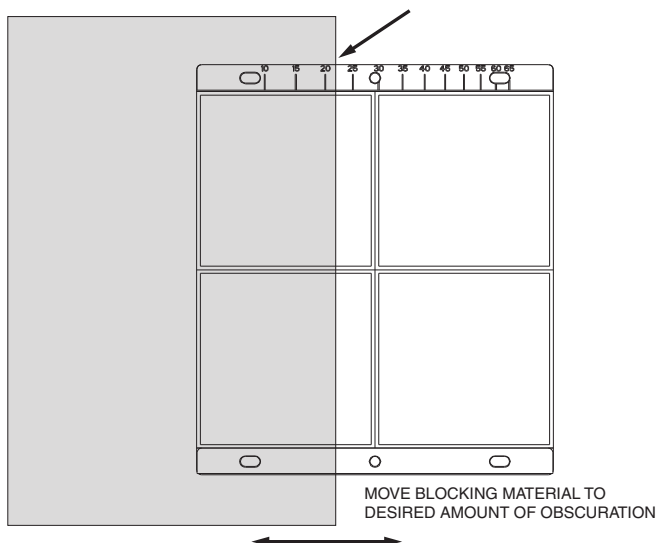
Detectors must be tested after installation and following periodic maintenance. The sensitivity of the 6500 may be tested as follows:

#### Calibrated Test Filter Method

The sensitivity of the detector can be tested using an opaque material (such as this manual) to cover the reflector by an amount indicated by the graduated scale on the reflector, see Figure 10.

1. Verify the sensitivity setting of the detector in % obscuration. See the Sensitivity Selection section of this manual for sensitivity determination if sensitivity is unknown.
2. Place the blocking material over the reflector, lining it up with the graduated marks that are 10 less than the detector setting in % obscuration. The detector should not alarm or fault. Keep the material in place for a minimum of 1 minute.
3. Place the blocking material over the reflector lining it up with the graduated marks that are 10 more than the detector setting in % obscuration. The detector should enter alarm within 1 minute.
4. The detector can be reset with the reset switch on the detector unit or remote reset.

LINE UP EDGE OF BLOCKING MATERIAL WITH APPROPRIATE OBSCURATION LEVEL



**Figure 10. Reflector Test Card Procedure**

### Test Failure Checks

If the detector fails either the sensitivity or functional test, several steps should be taken to determine if the detector is faulty or simply needs to be re-adjusted, before returning the unit. These steps include:

1. Verify all wiring connections and appropriate power is applied to the detector.
2. Verify that the optical line of sight is free from obstructions or any other light sources including reflective objects such as gloss painted surfaces.

It is imperative that at least 90% of the received light is from the reflector alone, otherwise sensitivity cannot be assured.

3. Apply the maintenance procedure in this manual. Repeat the test procedure. If the detector still fails the test procedure proceed with step 4.
4. Repeat the alignment procedure in this manual. If the alignment procedure is successful repeat the test procedure. If the detector still fails the test it should be returned for repair.

### 6500 BEAM DETECTOR: SET-UP PROCEDURE SUMMARY

**Beam Alignment** – ensure power is on

#### Course Alignment

Carry out using target eyepiece  
Adjust using horizontal and vertical thumb screws

#### Fine Adjustment

Initiate using **Alignment Switch**  
Continue adjustment using horizontal and vertical thumb screws  
When the adjustment is complete press the **Alignment Switch**

#### Sensitivity Setting

Select using **Sensitivity Switch**

**Final Gain Adjustment** – ensure front cover is fitted

Initiate using the **Reset Switch**  
Completed when the green LED blinks

#### Final Verification

Use obscuration filters or reflector test card to initiate *Fire* and *Fault* signals

### MAINTENANCE

*Note: Before cleaning the detector, notify the proper authorities that the smoke detector system is undergoing maintenance, and therefore the system will be temporarily out of service. Disable the zone or system undergoing maintenance to prevent unwanted alarms.*

1. Carefully clean the outer housing lens face. A damp soft cloth with a mild soap may be used. Avoid products with solvents or ammonia.
2. Carefully clean the reflector. A damp soft cloth with a mild soap may be used. Avoid products with solvents or ammonia.

### Functional Testing

For periodic maintenance functional testing, the detector can either be tested using the Calibrated Test Filter method, by using the local test switch on the transmitter/receiver unit or remotely using the Remote Test Station.

The Remote Test Station, RTS151KEY, can be used with the 6500 beam smoke detector. The wiring diagram to connect the 6500/S to the key is displayed on page 2 of this manual.

The 6500S is equipped with an integral sensitivity test feature that consists of a calibrated test filter attached to a servomotor inside the detector optics. When a test is initiated using the remote test station or local test switch the test filter is moved in the pathway of the light beam. If the correct level of signal reduction is received the detector will enter alarm. If the proper level of signal reduction was not achieved, indicating that the sensitivity of the detector is out of tolerance, the detector will enter the fault condition.

*Note: This test should satisfy most local periodic maintenance and testing requirements.*

If the detector fails this test refer to the Test Failure Checks described above

### PAINTING

The outer aesthetic ring may be painted using enamel or acrylic paints either by brush or spray.


*Note: Never paint the flat lens surface of the outer housing.*

Modes	Red See note below	Yellow	Green See note below	Remote Annunciator	Dual Digital Display	Initiating Means	Comments & Troubleshooting Tips
Normal	Off	Off	Blink	Blink	Off	Successful completion of initialisation or detector reset	
Alignment	Off	On	Blink	Blink	On, Relative amount of signal 0 – 99 or “-” if automatic gain resetting or “Lo” if signal is too low	Alignment switch	
Alarm	On	Off	Off	On	Off	Smoke, test filter, RTS151KEY, test stations	
Fault: Drift Comp limit reached	Off	3 Quick Blinks	Blink	Blink	Off	Long term drift reference out of range	- Clean detector and reflector
Fault: Signal over range	Off	2 Quick Blinks	Blink	Blink	Off	Increase of reflected signal	- Inspect line of sight between detector and reflector for reflective objects in beam path - Sunlight into reflector
Fault: Beam blockage response	Off	4 Quick Blinks	Blink	Blink	Off	Beam Blockage	- Remove blockage - Faulty Unit
Initialisation: Power on	Off	Blink until complete	Blink	Blink	Off	Apply power from discharged state	
Initialisation: Alignment exit	Off	Blink until complete	Blink	Blink	Off	Depressing RESET switch after alignment	
Local Test: Pass result	On	Blinks out amount of drift used	Off	On	Off	Panel or RTS151KEY	Remains in alarm until reset
Local Test: Fail result	Off	On until reset or timeout	Blink	Blink	Off	Panel or RTS151KEY	Remains in fault until reset or timeout

Note: The operation of the green and Red LEDs is dependent on control panel programming. For example the green LED may not be programmed to blink in “Normal” mode.

Blinks Output by Yellow LED once the Device has Passed a Local Test

Percent the detector has drifted	Number of blinks output
<10%	None
<20%	1
<30%	2
<40%	3
<50%	4
<60%	5
<70%	6
<80%	7
<90%	8
<100%	9



**0832  
6500(S)**  
DoP Ref:  
0832-CPD-0326 12  
EN54-12, EN54-17: 2005

Optical Beam Smoke Detector  
Intended for use in fire detection and fire alarm systems in and around buildings

System Sensor Europe  
Pittway Tecnologica Srl, Via  
Caboto 19/3, 34147 TRIESTE,  
Italy